

IPv6 Essentials Reference Sheet v1.8

IPv6 Addressing		
Address Type	IPv6 Notation	Binary Prefix
Unspecified	::128	0000...0 (128 bits)
Loopback	::1/128	0000...1 (128 bits)
Multicast	ff00::/8	1111 1111 xxxx xxxx
Link-Local	fe80::/10	1111 1110 1000 0000
Global Unicast (GUA)	2000::/3	001x xxxx xxxx xxxx
Unique Local (ULA)	fc00::/7	1111 110x xxxx xxxx
6to4 (tunnel)	2002::/16	
Teredo (tunnel)	2001:0000::/32	
IPv4-Mapped IPv6	0:0:0:0:ffff:a.b.c.d	
NAT64	64:ff9b::/96	
Documentation	2001:0db8::/32	

Well Known Multicast Addresses		
Address	Description	Scope
ff01::1	All Nodes Address	Interface-local
ff02::1	All Nodes Address	Link-local
ff01::2	All Routers Address	Interface-local
ff02::2	All Routers Address	Link-local
ff05::2	All Routers Address	Site-local
ff02::4	DVMRP Routers	Link-local
ff02::5	OSPF IGP Drothers	Link-local
ff02::6	OSPF IGP DRs	Link-local
ff02::9	RIPng Routers	Link-local
ff02::a	EIGRPv6 Routers	Link-local
ff02::c	Microsoft SSDP	Link-local
ff02::d	All PIM Routers	Link-local
ff02::12	VRRPv3	Link-local
ff02::16	All MLDv2 Routers	Link-local
ff02::1:2	DHCPv6 Servers/Agents	Link-local
ff05::1:3	DHCPv6 Servers/Agents	Site-local
ff0x::101	Network Time Protocol	Variable
ff02::1:ffxx:xxxx	Solicited-Node Address	Link-local

ICMPv6 Message Types	
128	Echo Request
129	Echo Reply
130	Multicast Listener Query
131	Multicast Listener Report
132	Multicast Listener Done
133	Router Solicitation
134	Router Advertisement
135	Neighbor Solicitation
136	Neighbor Advertisement
137	Redirect Message
138	Router Renumbering
139	ICMP Node Information Query
140	ICMP Node Information Response
143	Multicast Listener Report (MLDv2)
144	Home Agent Discovery Request
145	Home Agent Discovery Reply
146	Mobile Prefix Solicitation
147	Mobile Prefix Advertisement

IPv6 Next Header Fields (Extension Headers)	
0	IPv6 Hop-by-Hop Option
41	IPv6 encapsulation
43	Routing Header for IPv6
44	Fragment Header for IPv6
50	Encap Security Payload (ESP)
51	Authentication Header (AH)
59	No Next Header for IPv6
60	Destination Options for IPv6

Wireshark Display Filters for IPv6	
ipv6	all IPv6 traffic
icmpv6	all IPv6 ICMPv6 traffic
dhcpv6	all DHCPv6 traffic
icmpv6.type == 133	all router solicitations
icmpv6.type == 134	all router advertisements
icmpv6.type == 135	all neighbor solicitations
icmpv6.type == 136	all neighbor advertisements
icmpv6.type == 137	all redirect messages

IPv6 Address Shorthand Notation
2001:0db8:0006:1ab5:0000:0000:0000:ba11 remove leading zeros to achieve 2001:db8:6:1ab5:0:0:0:ba11 additional reduction by replacing consecutive fields of zeros with double-colon "::" option (can only be done once) to achieve 2001:db8:6:1ab5::ba11

IPv6 Header			
Version (4)	Traffic Class (8)	Flow Label (20)	
Payload Length (16)		Next Header (8)	Hop Limit (8)
Source Address (128)			
Destination Address (128)			
Version : IP version number, 6 for IPv6 Traffic Class : Similar to IPv4 ToS field. Used by nodes to identify and distinguish between different classes or priorities of IPv6 packets Flow label : Used by a source to label sequences of packets for which it requests special handling by the IPv6 routers Payload Length : Length of the IPv6 payload (may also include extension headers) Next Header : Identifies the type of header following the IPv6 header Hop Limit : Decremented by 1 by every router that forwards the packet Source Address : IPv6 address of the originator of the packet, will be a unicast address Destination Address : IPv6 address of the intended recipient or final destination of the packet, can be unicast or multicast address			

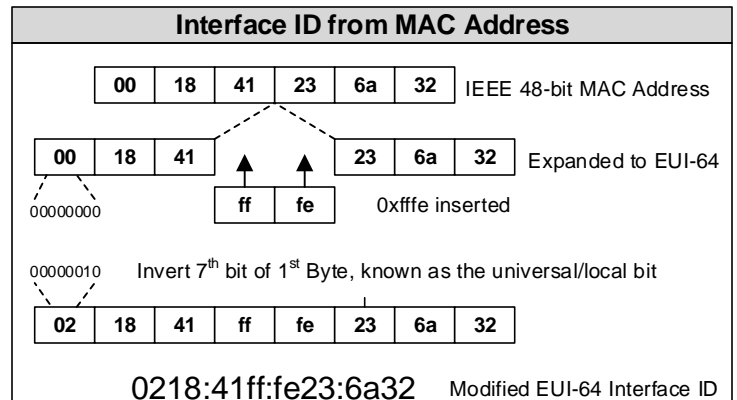

IPv6 Address Types
Link-Local – Automatically assigned per interface, not routable
Global Unicast Address (GUA) – Assigned by SLAAC, Stateful (DHCPv6), or manual, routable to Internet
Unique Local Address (ULA) – Assigned by SLAAC, Stateful (DHCPv6), or manual, not routable to Internet, is routable within enterprise (like private address)
Unicast – one-to-one (link-local, unique local, global)
Anycast – one-to-nearest (allocated from Unicast)
Multicast – one-to-many (also replaces broadcast)

IPv6 Neighbor Discovery Protocol
Neighbor Solicitation (NS) – Neighbor address resolution (similar to IPv4 ARP)
Neighbor Advertisement (NA) – Response to Neighbor Solicitation requests
Router Solicitation (RS) – Sent by nodes "looking" for IPv6 routers on-link
Router Advertisements (RA) – Sent periodically by routers and in response to RS
Duplicate Address Detection (DAD) – Sent to own Solicited-Node Multicast Address